



BioGill – Onsite Biological Wastewater Treatment Systems

Igor Linde
Regional Sales Manager-Europe



Company Snapshot

- BioGill manufactures above-ground, biological bioreactors for onsite wastewater treatment
- Offices in the US, Australia, China and Germany
- Manufacturing in Malaysia and Germany
- Patented attached growth bioreactors with innovative nanoceramic media
- BioGill reactors excel at reducing high organic loads & BOD in wastewater, ideal for food & beverage
- Modular, scalable systems
- Robust, low energy, & simple to operate with minimized lifecycle costs
- BioGill works with best in class industry partners to deliver complete customer solutions tailored to local requirements

Our Vision

To be the global leader in biological wastewater treatment technologies.

Our Mission

To combine the latest science and technology in the manufacture of nano-ceramic media, known as gills, to create the most useful and cost-effective wastewater treatment systems.

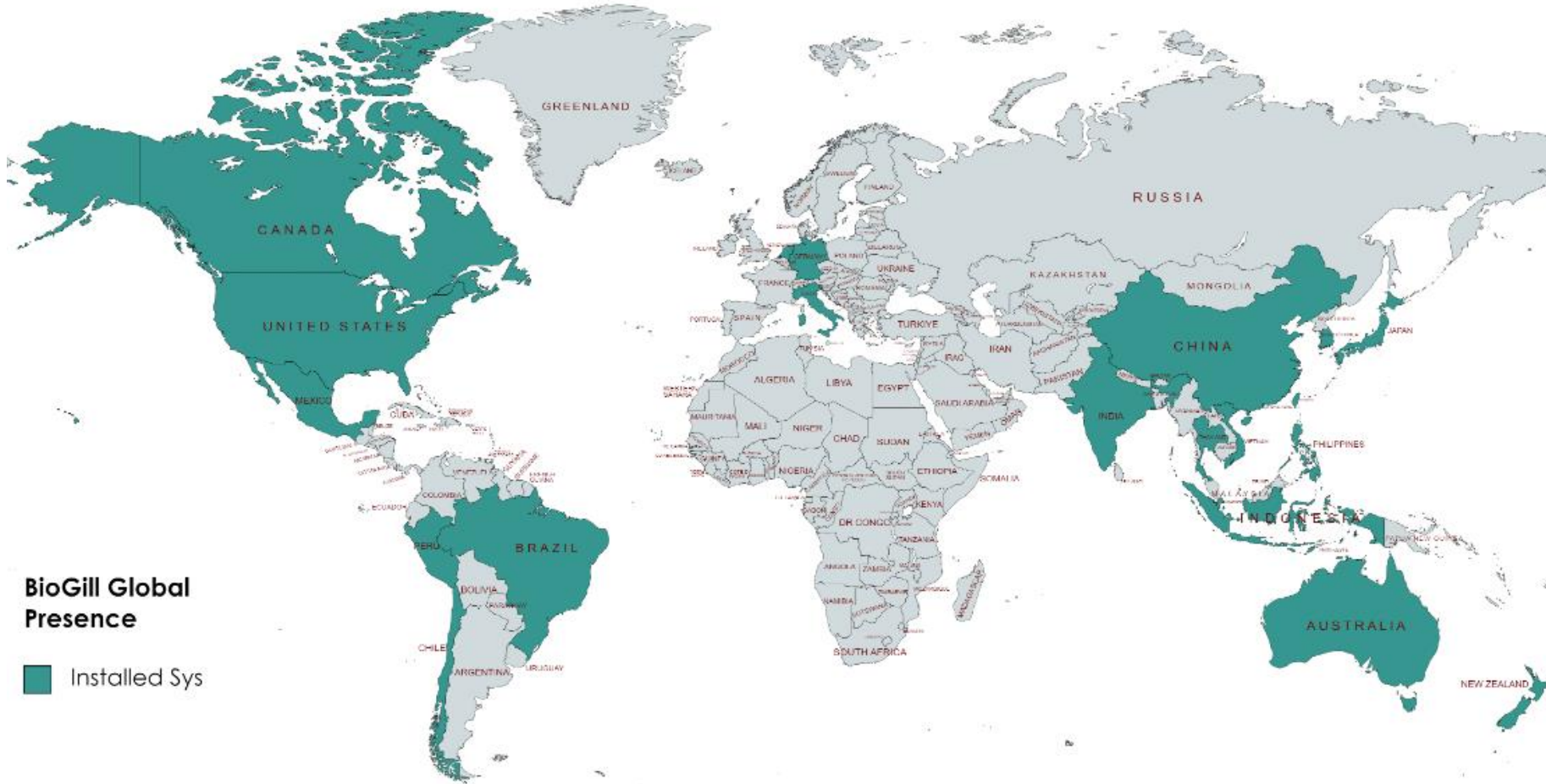

BioGill Global Presence

 Installed Sys

- | | |
|-------------|-------------|
| China | USA |
| Thailand | Mexico |
| Japan | Canada |
| Singapore | Belize |
| Taiwan | Peru |
| Vietnam | Brazil |
| India | Chile |
| South Korea | Middle East |
| Indonesia | Netherlands |
| Philippines | Italy |
| Australia | Germany |
| Cook Island | |
| Fiji | |
| Samoa | |
| New Zealand | |

+300 references

2005: Technology developed by researchers at Australian Government Science Organization (ANSTO)

2009: BioGill founded

2012: BioGill named in Top 50 most promising high tech wastewater companies

2012: First commercial installations

2014: First exports to Asia

2015: Top 100 Environmental Technology, China

2016: 2nd generation BioGill Tower released

2017: New offices opened in US & China

2018: "Best Challenger" in Innovation Awards
Ministry of Science & Technology, China
BioGill named in APAC Top 25

2019: Awarded Top Ten Innovator, Imagine H2O, USA
Gold Hermes Creative Advertising Award (USA)
BioGill Ultra launched

2021: BioGill Acquired By BW Water (part of the BW Group)

2023: New products introduction – MAX series, all made in SS

2024: Established sales office and manufacturing in
Germany under BW Water GmbH



- 1 Inlet: Wastewater is pumped into the dispersion manifold
- 2 HydroSwirl™: Non-clog dispersion head distributes flow evenly over gills
- 3 Gills: Microbes grow on both sides of the semi permeable gills.
- 4 Air Vent: Natural convection currents generated by heat from the biomass pull air through the unit.
- 5 Outlet: Treated water flows by gravity into the recirculation tank

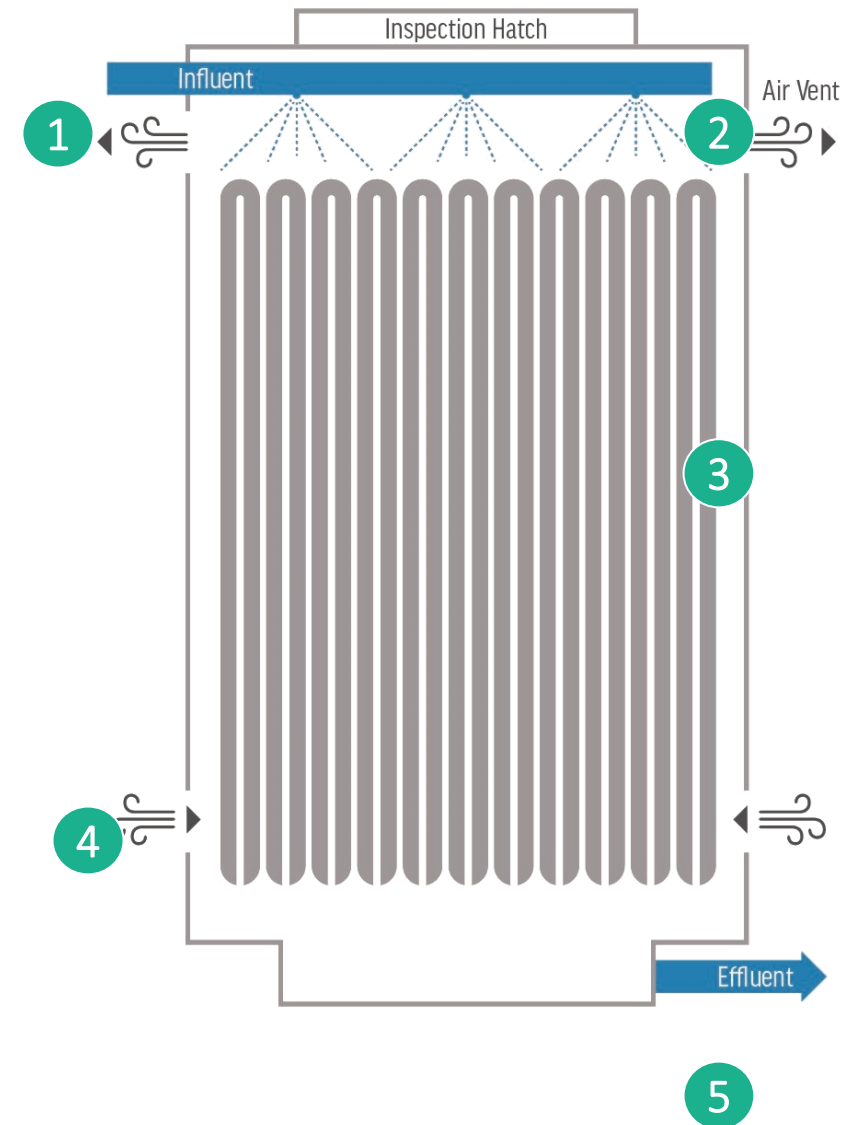

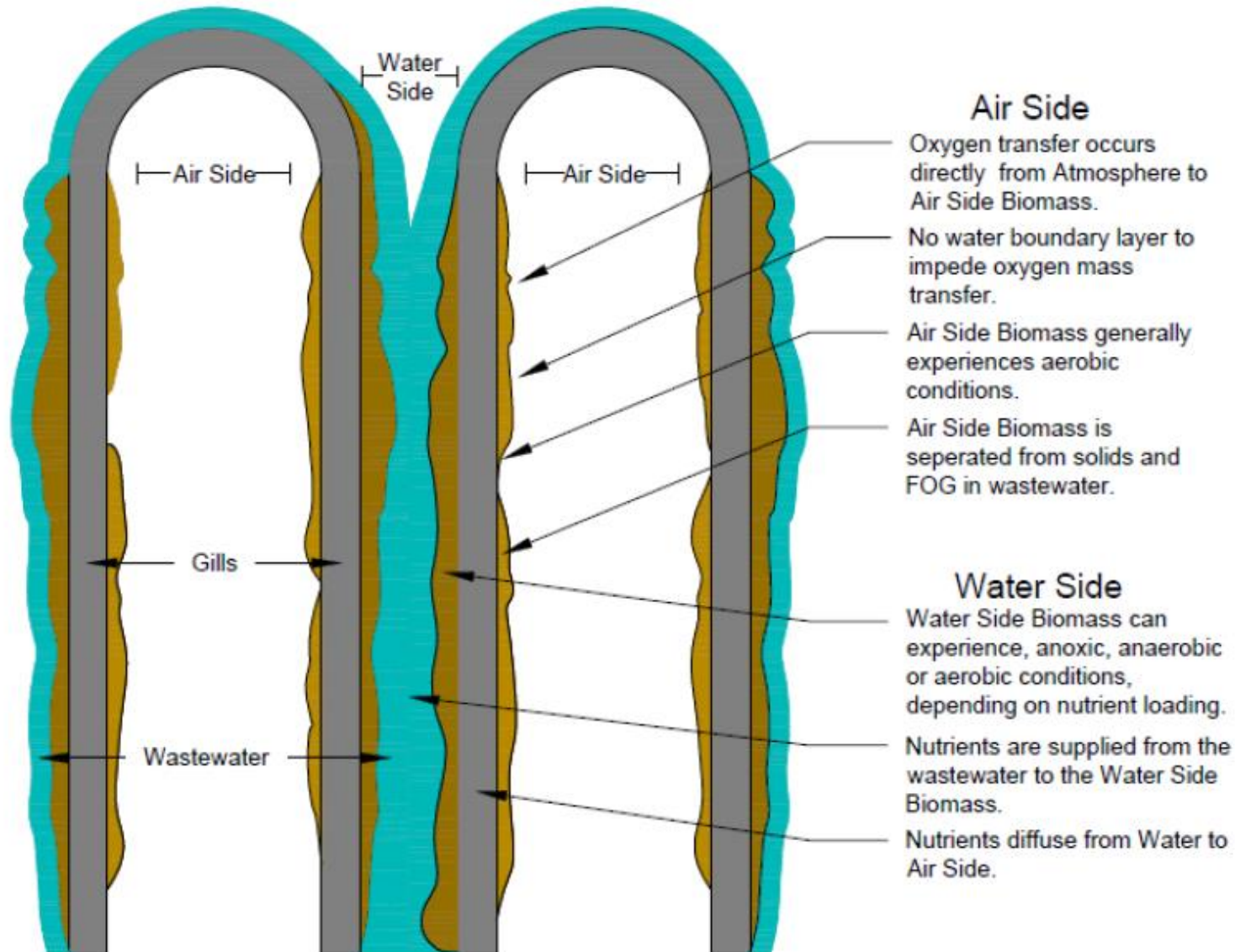

The cartridge is the building-block of all BioGill products.

- Maximum cartridge treatment capacity is based on the maximum amount of biomass that can be sustained on the gills.
- Actual capacity per cartridge is based on the flow and BOD concentration (BOD mass loading) of the incoming wastewater.
- Consult your BioGill representative to assist you with determining the appropriate removal for your specific application.



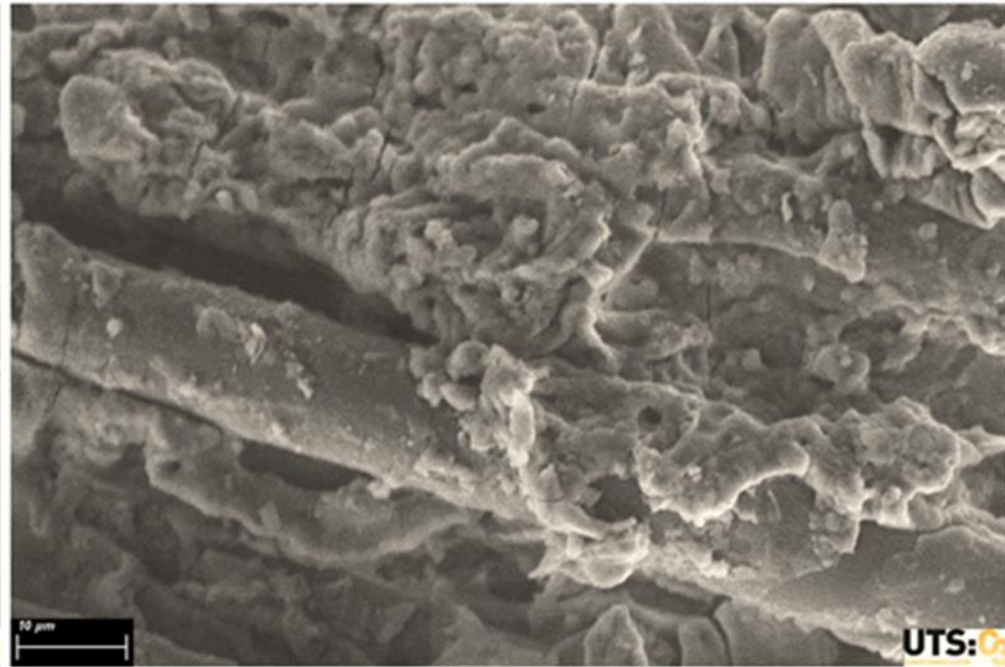

SEM image, new Gill

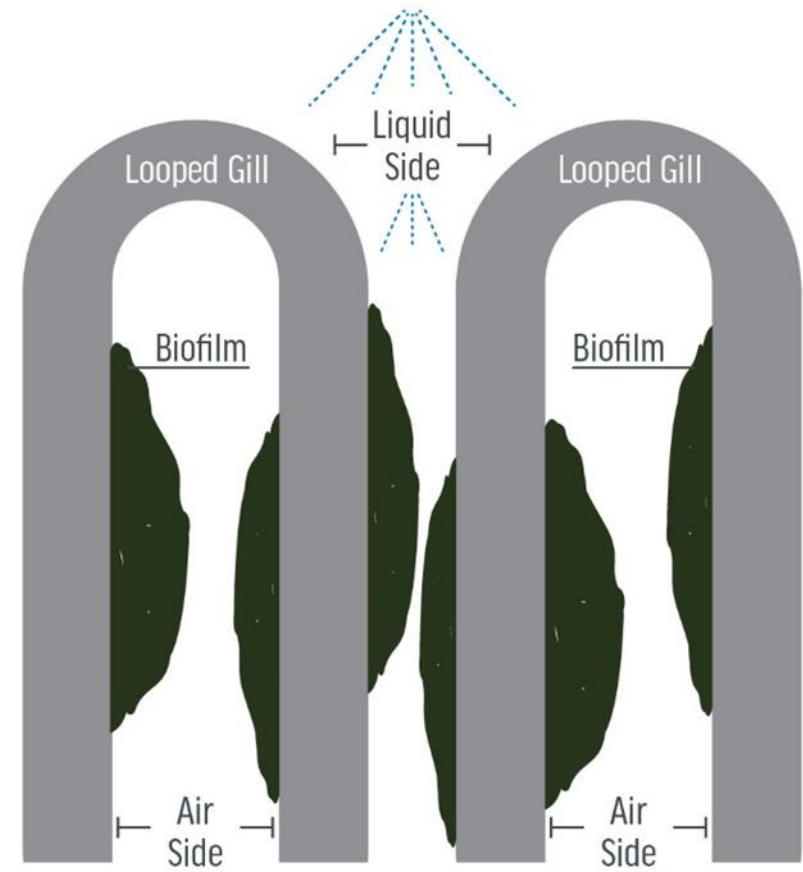

- Patented non-clog Hydroswhirl provides even distribution over all of the filter media

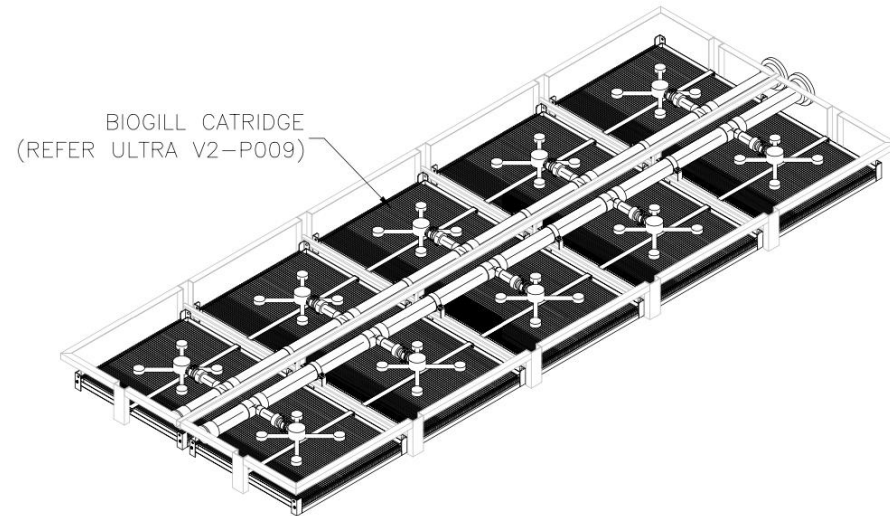

3 ISOMETRIC 2
Scale: N.T.S



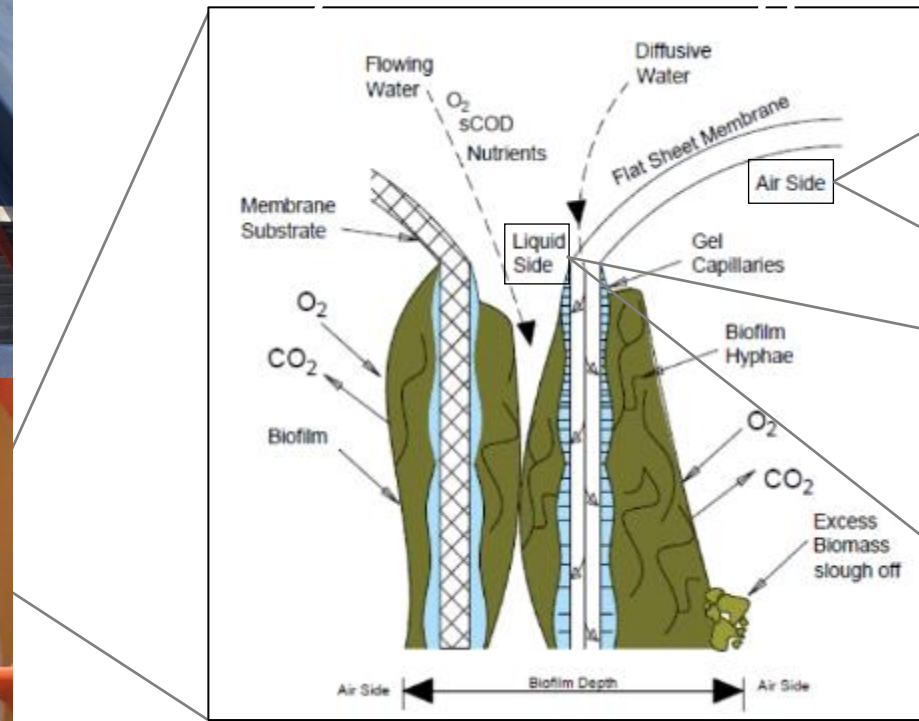

Typical BioGill Biofilm Profile



Air Side vs. Liquid Side of a Gill

- Counter diffusion as oxygen and nutrients come from opposite sides of the “gill” membrane.
- Creates different regions
- Low sludge yield Sludge yield between 0.1-0.2 kg TSS/kg BOD were observed which is much lower than conventional biological treatment sludge yields

Above Images Show:

- Air side: lighter brown aerobic biomass
- Water side: darker anaerobic biomass

- **(Side-streaming of high strength waste sources if needed or desired)**
- **Solids Removal**
 - Physical/chemical removal of solids & insoluble BOD
 - e.g. Screening, settling
- **Equalization:** Moderate variability in flow, organics, pH
- **pH Correction**
- **Biological Treatment**
 - Biological removal of soluble BOD

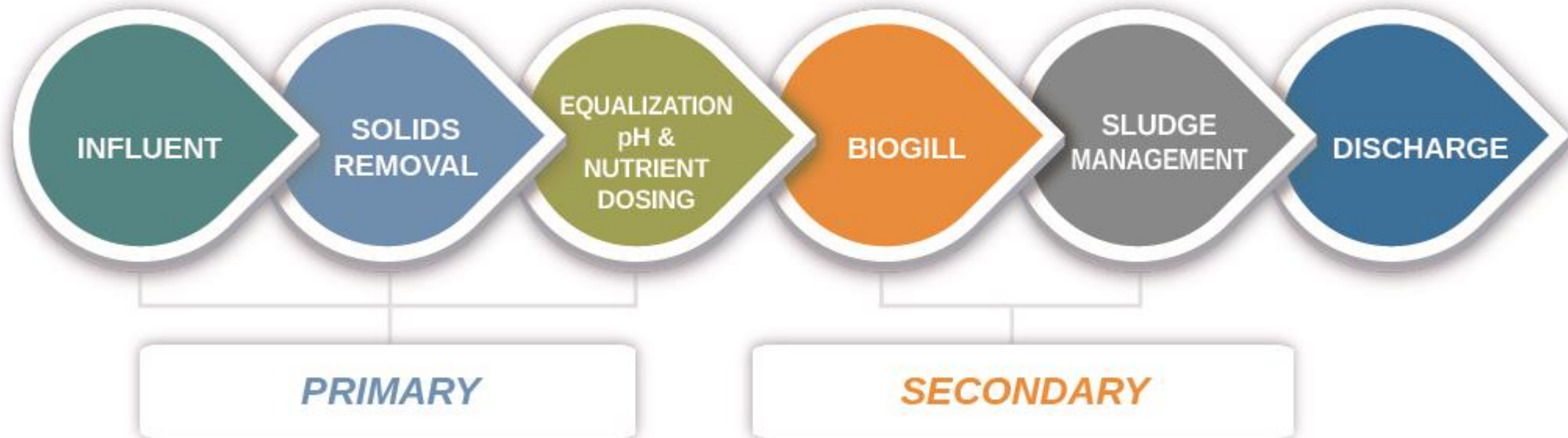

BioGill Inlet Wastewater Quality Parameters	Required Range (needs to be met by proper pre-treatment)
Temperature Range	65-100 °F 18-37 °C
pH Range	6.5-8.5
Optimum C:N:P Ratio	100:10:1 to 100:5:0.5
TSS	<300 mg/L
FOG	<100 mg/L

KEY FEATURES



Simple to install & operate



Easy to maintain

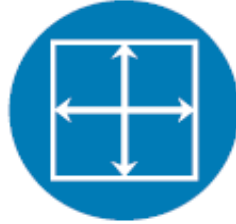

Modular & scalable



Low sludge output



Aerobic and anaerobic treatment in the same pass

BIOGILL BENEFITS



Effective & rapid treatment of high strength BOD



Boost performance of existing plants



Resistant to shock loads & high organic waste streams



Low energy & operating costs



Low odor



Compact onsite treatment



BioGill® Media	BioGill® Tower/Prime	BioGill® Max Series (2022 Release)	BioGill® Ultra
<p>Made to order for custom projects</p>	<p>Attached growth, above-ground bioreactor.</p> <p><i>2 to 10 m3/day treated per Tower</i></p> <p><i>Typical project: 1 to 6 Towers</i></p>	<p>Packaged biological reactor with built-in internal piping, recirculation tanks, recirculation pumps, and control box.</p> <p>Available in Max 2, Max 4 and Max 6</p> <p><i>4 to 40 m3/day treated per Max</i></p> <p><i>Typical project: 1 to 6 Max units</i></p>	<p>“Plug & play” biological treatment system for higher flows. Stand-alone container with built-in internal piping, recirculation tanks, pumps, and control panel.</p> <p><i>20 to 70 m3/day treated per Ultra</i></p> <p><i>Typical project: 1 to 6 Ultras</i></p>

The HydroSwirl™ manifold: Efficient, consistent, effective dispersal coverage

Feature: **High clog resistance**, with particle tolerance up to 10 mm

HydroSwirl™ uses two mechanisms to achieve its dispersal pattern.

- 1) A centrifugal chamber is used to rotate the water
- 2) A spinning deflector ensures that the water is dispersed evenly across the gill surface. Optimal flow rate is 6 - 12 m³/hr.

Benefit:

HydroSwirl™ has been designed to be foul free, improving coverage and allowing for easier maintenance.

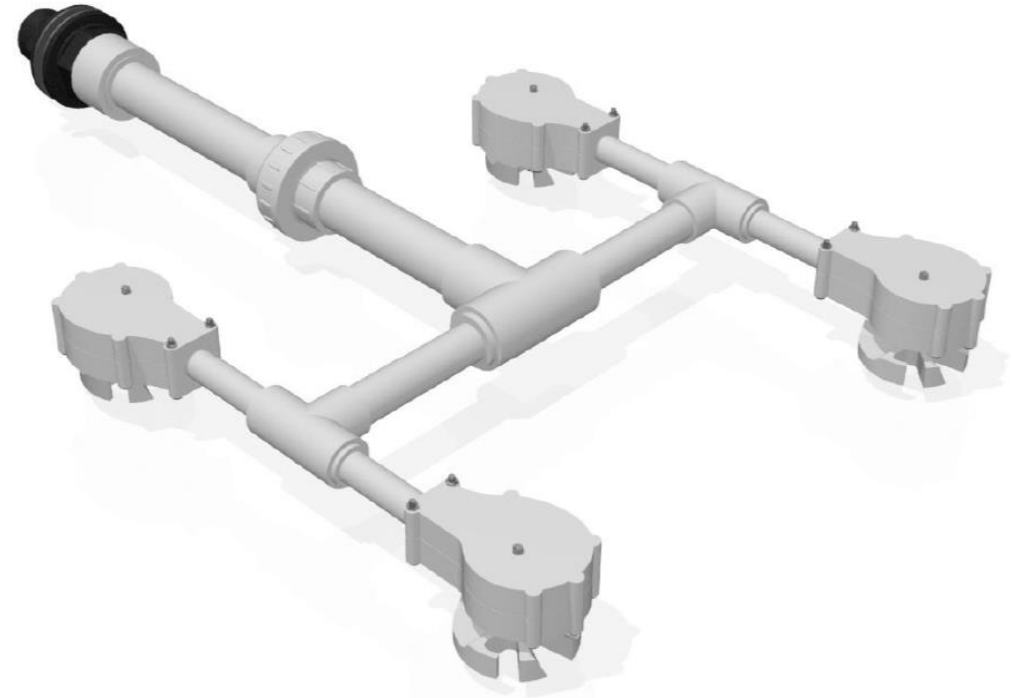
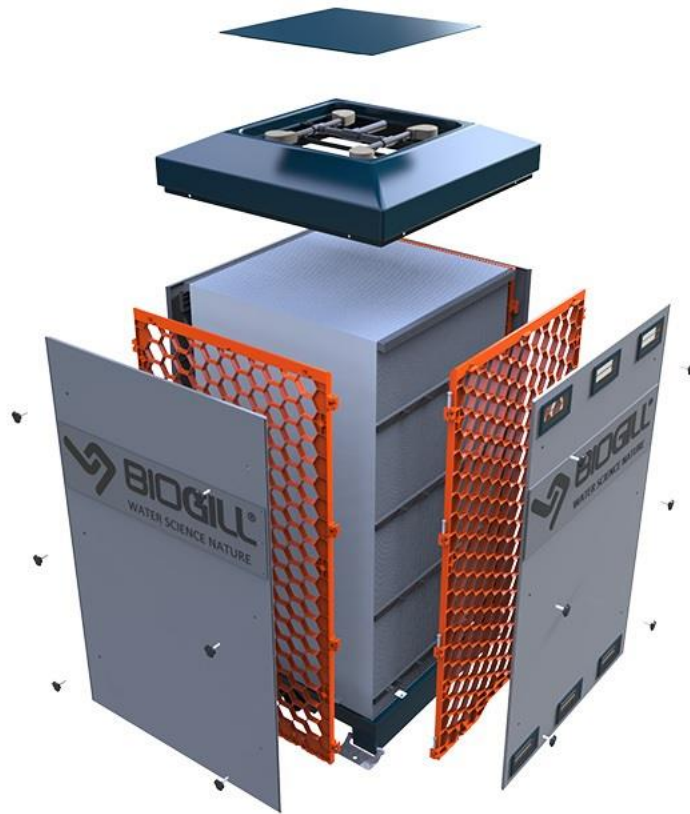

Figure 1- Render of the HydroSwirl™ Manifold

BioGill Tower/Prime



Old design

- Flow per unit per project determined by wastewater temperature, percent removal required, and system configuration.

PRODUCT DETAILS	
Gill Surface Area per Unit	230m ² 2474ft ²
Dimensions	2252mm(H) x 1155mm(L) x 1155(W) 88.7"(H) x 45.47"(L) x 45.47"(W)
Optional Extras	Stand Recirculation Pump Recirculation Tank
Brewery and Winery Application BOD influent 4,000mg/L to BOD effluent <300mg/L, 30°C 86°F	Typical Project: 1-6 Towers 0.5-12m ³ /day 132-3,200gal/day
Sewage Application BOD influent 250mg/L to BOD effluent <30mg/L, 25°C 77°F	Typical Project: 1-6 Towers 4-50m ³ /day 1,050-13,200gal/day

New Release: **BioGill Prime**

- Load: Up to 9.75kg BOD/Day
- Inlet Connection: 2-in(DN50) PVC (into rotomold tank)
- Outlet Connection : 2-in PVC (DN50) (out of rotomold tank)
- Solids wasting: 2-in (DN50) PVC
- Stainless steel construction and stand
- Comparable cost vs Tower
- Dimensions
 - L:7.9' W: 3.9' H: 10'5
 - L:2400 W:1200 H: 3220 – includes recirculation tanks

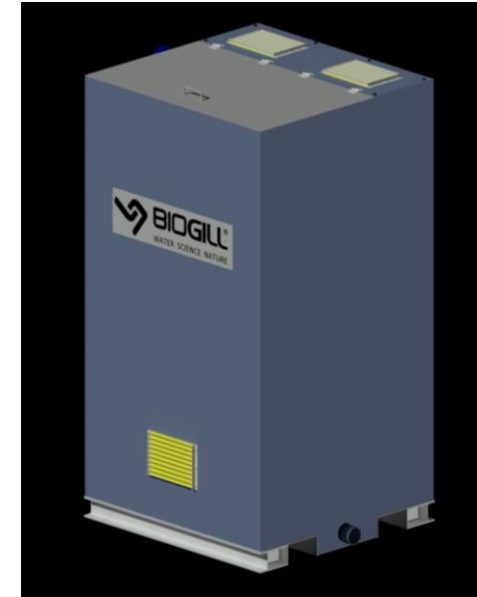

BioGill Max Series



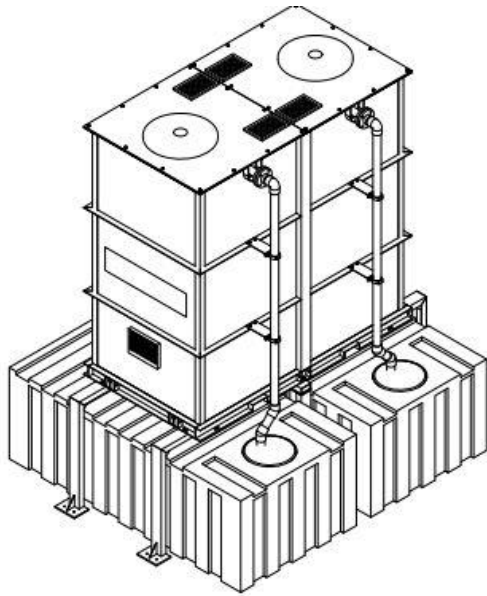

SS, RF
OUTLET

ISOMETRIC
Scale: 1:20

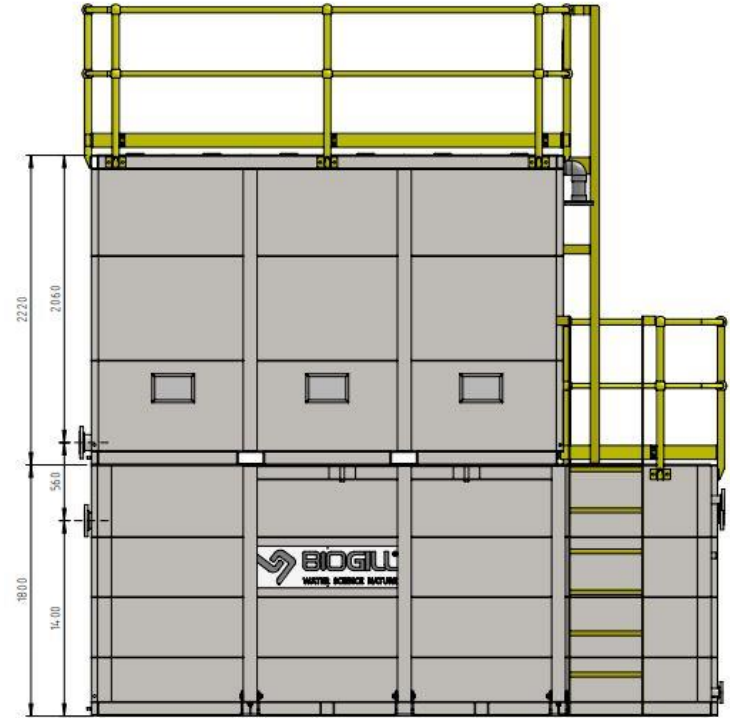
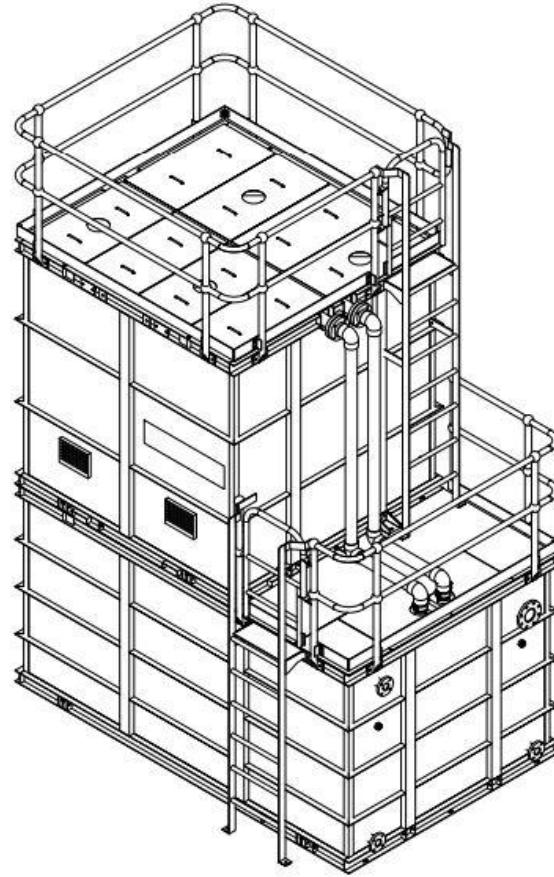

BioGill Max 2

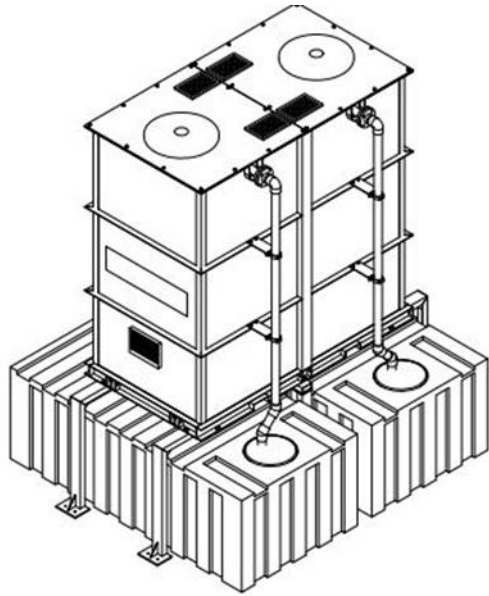

10.00"
OUTLET

ISOMETRIC
SCALE: 1:30

- Flow per unit per project determined by wastewater temperature, percent removal required, and system configuration.

PRODUCT DETAILS

Gill Surface Area per Unit	460m ² 4948ft ²
Dimensions	2275mm(H) x 2200mm(L) x 1500mm(W) 7.5'(H) x 7.2'(L) x 4.9'(W)
Optional Extras	Recirculation Pump Recirculation Tank Control Panel
Brewery and Winery Application BOD influent 4,000mg/L to BOD effluent <300mg/L, 30°C 86°F	Typical Project: 1-4 Max 2 1-15m ³ /day 500-4000gal/day
Sewage Application BOD influent 250mg/L to BOD effluent <30mg/L, 25°C 77°F	Typical Project: 1-4 Max 2 8-50m ³ /day 2,100-13,000gal/day

BioGill Max 4

- Flow per unit per project determined by wastewater temperature, percent removal required, and system configuration.

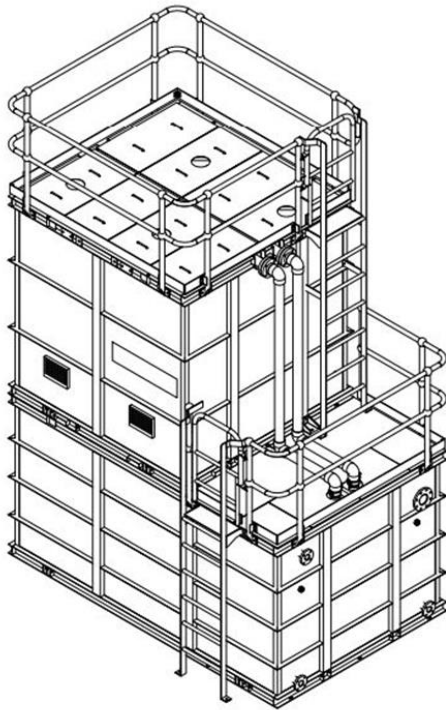

PRODUCT DETAILS

Gill Surface Area per Unit	920m ² 9896ft ²
Dimensions	2200mm(H) x 2550mm(L) x 2200(W) 7.2'(H) x 8.4'(L) x 7.2'(W)
Optional Extras	Recirculation Pump Recirculation Tank Control Panel
Brewery and Winery Application BOD influent 4,000mg/L to BOD effluent <300mg/L, 30°C 86°F	Typical Project: 1-4 Max 4 2-30m ³ /day 1,000-8,000gal/day
Sewage Application BOD influent 250mg/L to BOD effluent <30mg/L, 25°C 77°F	Typical Project: 1-4 Max 4 16-100 ³ /day 4,200—26,500gal/day

BioGill Max 6

- Flow per unit per project determined by wastewater temperature, percent removal required, and system configuration.

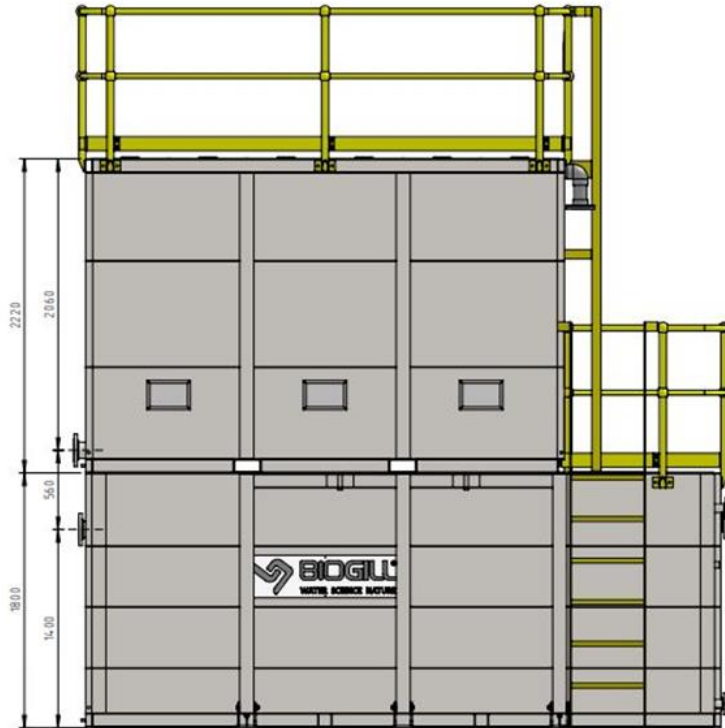

Product Details	
Gill Surface Area per Unit	1380m ² 14854ft ²
Dimensions	2200mm(H) x 3400mm(L) x 2200(W) 7.2'(H) x 11.2'(L) x 7.2"(W)
Optional Extras	Recirculation Pump Recirculation Tank Control Panel
Brewery and Winery Application BOD influent 4,000mg/L to BOD effluent <300mg/L, 30°C 86°F	Typical Project: 1-4 Max 6 7-40m ³ /day 2,000-11,000gal/day
Sewage Application BOD influent 250mg/L to BOD effluent <30mg/L, 25°C 77°F	Typical Project: 1-4 Max 6 40-170m ³ /day 10,500—45,000gal/day

BioGill Ultra



- Flow per unit per project determined by wastewater temperature, percent removal required, and system configuration.

Product Details	
Gill Surface Area per Unit	1650m ² 17,760ft ²
Dimensions	2.2m(H) x 8.7m(L) x 2.2m(W) 7.2'(H) x 28.5'(L) x 7.2'(W)
Inclusions	Recirculation Pumps Control Box PLC & Ultra Clean
Optional Extras	Remote Monitoring
Brewery and Winery Application BOD influent 4,000mg/L to BOD effluent <300mg/L, 30°C 86°F	Typical Project: 1-3 Ultras 12.5-60m ³ /day 3,300-15,900gal/day
Sewage Application BOD influent 250mg/L to BOD effluent <30mg/L, 25°C 77°F	Typical Project: 1-6 Ultras 50-360m ³ /day 13,200-95,100gal/day

Food &
Beverage



Sewage



Aquatic



Aquaculture



Maritime



**Low-Medium Flow/High
Load**

Target Clients

- Food & beverage
 - High BOD
 - Low to medium flow
 - <200 m³/day
 - Breweries
 - Wineries
 - Cideries/Juice
 - Bakeries
 - Dairies
 - Meat Processors
- Decentralized sewage
 - Resorts
 - Campgrounds
 - Small community

Client Drivers

- Compliance
- Reduce Sewer Fees & High Strength Surcharges
- Low Operation
- Low Maintenance
- Scalable Systems
- Upgrade existing plant
- Minimal site disruption

BioGill Benefits

- Readily available designs
- Easy to Install
- Simple to Operate
- Low OPEX
- Easy to Maintain
- Modular & Scalable
- No Odor

Where does BioGill fit best?

- High strength, low to medium flow!
- Typically: 1-200 m³/day wastewater
- Breweries: 50,000-6,000,000 litres/year
- Wineries: 1,000-250,000 cases/year 9,000-2,250,000 l/a
- High soluble BOD: up to 10,000 mg/l influent
- Up to ~95% design BOD removal
- Can be used as roughening, paired with other biological technology (e.g. MBR) for reuse or retrofit
- Customers anticipating rapid growth

